

AutoMixte Combined Hybrid

« HYBRID 12m BUS »

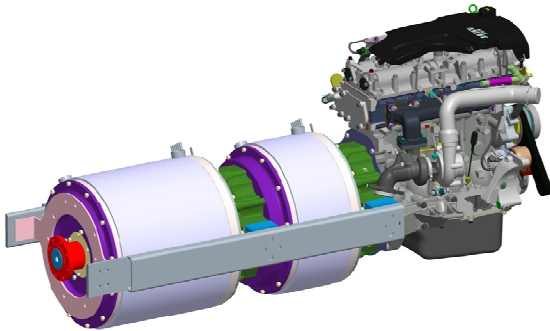

The PROJECT

- AutoMixte hybrid topology dedicated to heavy-duty urban vehicles (Bus, Garbage trucks)
- Combined hybrid for an extended high efficiency suitable for various routes and loads

Combined series-parallel plug-in HYBRID

- **Electric Motors**
Motor 120 kW nom. 160 kW peak
Generator 40 kW nom.
Variable reluctance motors
- **Thermal Engine**
Diesel 3,0l, 400 N.m, 130 kW
Euro V
- **Batteries**
Li-Polymer, 300 kg.
533V, 70 A.h, 300 kW peak



PERFORMANCES

- **30 km range on batteries**
- **-25% to -40% CO₂ cut**

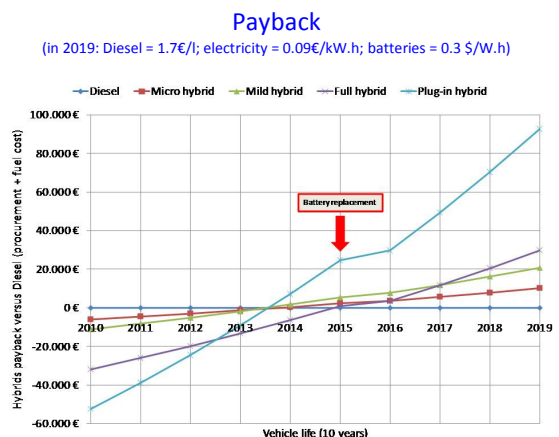

GREEN PROPULSION Ltd.

Av. Pré-Aily 20 ■ 4031 Angleur ■ Belgium

TEL: +3242397040 ■ FAX: +3242397049

info@greenpropulsion.be ■ www.greenpropulsion.be