

ZEV Delivery

« Hybrid Kangoo »



The PROJECT

- Hybridization of urban delivery
- Combined hybrid for extended high efficiency (urban and extra-urban cycle)
- Maximal CO₂ emission cut on driving cycle « The Post »

Combined series-parallel Plug-in HYBRID

■ Electric Motors

Motor 45 kW max, 45 kg
Generator 12 kW nom., 38 kg

■ Thermal Engine

Renault 1.5dCi 70

■ Batteries

Li-ions, 96 kg, 40 A.h. 260 V

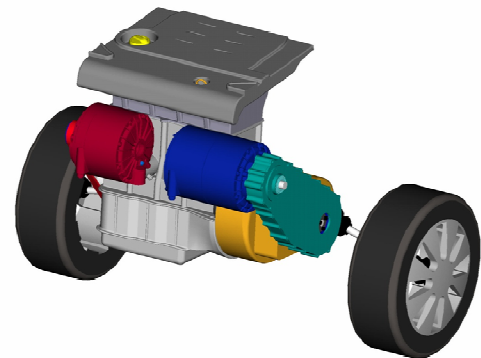

- Generator
- Motor/Generator
- Clutch + Differential

PERFORMANCES

- >50 km range on batteries
- 85g/km CO₂ thermal equivalent
93g/km well to wheel (-42%)
- -75% CO₂ on typical « The Post » cycle

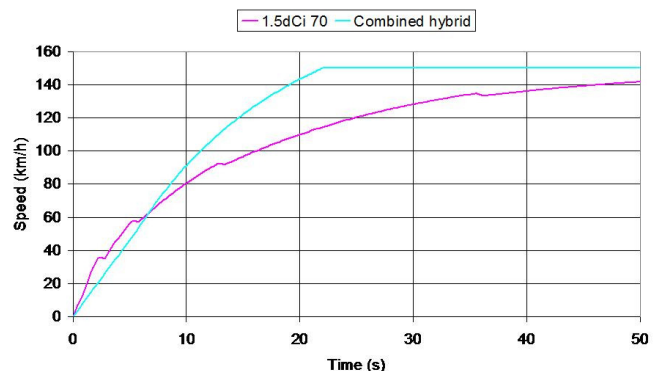

GREEN PROPULSION Ltd.

Av. Pré-Aily 20 ■ 4031 Angleur ■ Belgium

TEL: +3242397040 ■ FAX: +3242397049

info@greenpropulsion.be ■ www.greenpropulsion.be